

Vent Silencers

Vent Silencers reduce the noise produced by the expansion of gas or steam from elevated pressures to atmospheric pressure. These absorptive silencers are used to suppress noise generated by high velocity gas streams such as steam vents, safety relief valve outlets, system blow downs and purge outlets. Each vent silencer is designed to attenuate the noise level to the required sound pressure level criteria at a given distance from the silencer.

Model IVS - Acoustic Diffuser & Expansion Attenuation - 30 dB

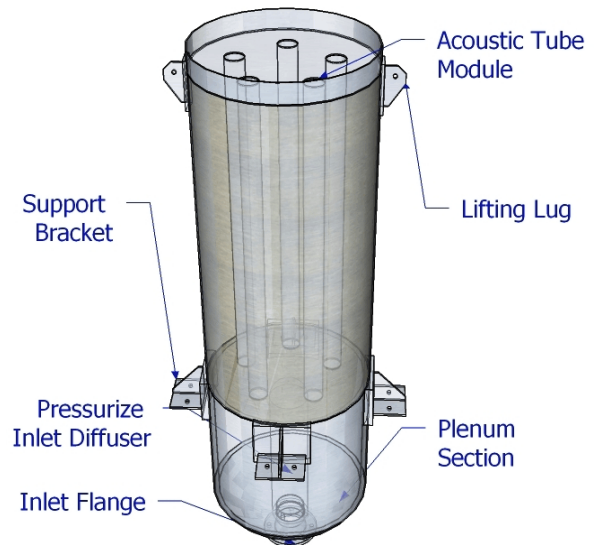

SELECTION GUIDELINES

Use the following design information from the valve data sheet for system analysis and silencer selection:

1. Type of gas
2. Molecular weight or specific gravity
3. Ratio of specific heats
4. Flow rate (lb/hr, ACFM or SCFM)
5. Pressure and temperature upstream of valve and silencer
6. Maximum allowable pressure drop (PSI) for valve and silencer
7. Manufacturer's name, and valve type and size
8. Unsilenced noise levels from valve (if available)
9. Silenced noise level (required at desired distance from source)
10. Silencer inlet size and pressure rating
11. Inlet orientation, axial or side
12. Silencer orientation, vertical or horizontal
13. Piping arrangement, including schematic if available
14. Other required options

APPLICATIONS

Vent silencers effectively silence high-velocity air, steam, and gas vents and blowdowns to atmosphere where sonic or critical conditions exist in the valve or pipes. Typical applications include:

- steam boiler relief valves
- superheater header relief valves
- boiler startup and purge
- high-pressure air vents
- natural gas blowdowns
- switch valves
- compressor blowoffs
- autoclaves
- steam ejectors

CONSTRUCTION

Typical vent silencers are welded heavy-duty units. The inlet nozzle and diffuser are constructed of steel and are welded. The diffuser provides controlled pressure expansion to atmosphere and uniform flow distribution through the acoustic section of the silencer. The lined inlet plenum (expansion chamber) of the silencer is designed with a double shell separated by a layer of acoustic insulation and sound-deadening material. The inner shell is solid to prevent shell radiated noise and migration of the acoustic fill. The transmission loss across the plenum and bottom head is comparable to the silencer attenuation.



Model IVS-30

Acoustic Diffuser & Expansion

DESCRIPTION

Vent Silencers reduce the noise by shifting the low frequency band to a higher frequency band where the acoustic pack material functions most efficiently. After the gas or steam is diffuse, it accumulates in the expansion chamber. Where performance dictates, double wall construction will be constructed. These silencers have internal erosion resistant acoustic material for high performance broad band attenuation, protected by heavy duty perforated sheet.

APPLICATIONS

As already stated, these units can be used for noise control of gas or steam flows to atmosphere. In the event that you are tasked with the responsibility and designing and selecting an exhaust silencer and piping arrangement, ISTIQ can provide direct assistance. If all of the details are supplied, ISTIQ will input this information and provide you with our own computer print-out detailing specific recommendations for the exhaust system.

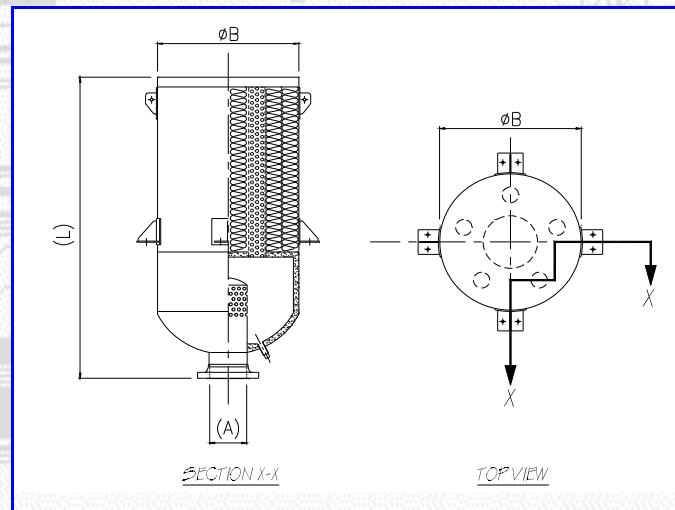

DIMENSION IN MM							
PIPE DIAMETER (A)	OVERALL DIAMETER (B)	OVERALL LENGTH (L)	WEIGHT (Kg)	PIPE DIAMETER (A)	OVERALL DIAMETER (B)	OVERALL LENGTH (L)	WEIGHT (Kg)
100	250	1500	70	450	915	3350	1200
125	300	1850	95	610	1220	4320	1500
150	350	2000	120	750	1500	4500	1800
200	450	2100	180	800	1670	4700	2000
250	510	2230	250	900	1760	4800	2200
300	610	2410	300	1000	1850	4800	2500
350	760	2720	410	1200	2500	5000	2800

ATTENUATION								
FREQUENCY (Hz)	63	125	250	500	1k	2k	4k	8k
dB	13	17	24	36	44	46	43	40